

### Lid Closer Options



Bolted



Victualic

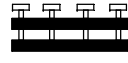

Tee Handle

\* Cover Selection Depends Upon Pressure Rating

SPECIFICATIONS	
Body: FRP / PVC	Max. Press: 50 PSI
Basket: 304 SS 1/8" Perf	Max. Temp: 140 Deg. F
Basket Mtrl: Flg.-12 GA / Perf-18 GA	Basket / Pipe Area: 13 : 1
Gasket: Neoprene	Open Basket Area = 5.2 : 1
Inlet: 14" 150# ANSI Flange	Cover : 1.500" Acrylic With 1/2" Vent
Outlet: 14" 150# ANSI Flange	Lid Closer: Tee Handles 304 SS

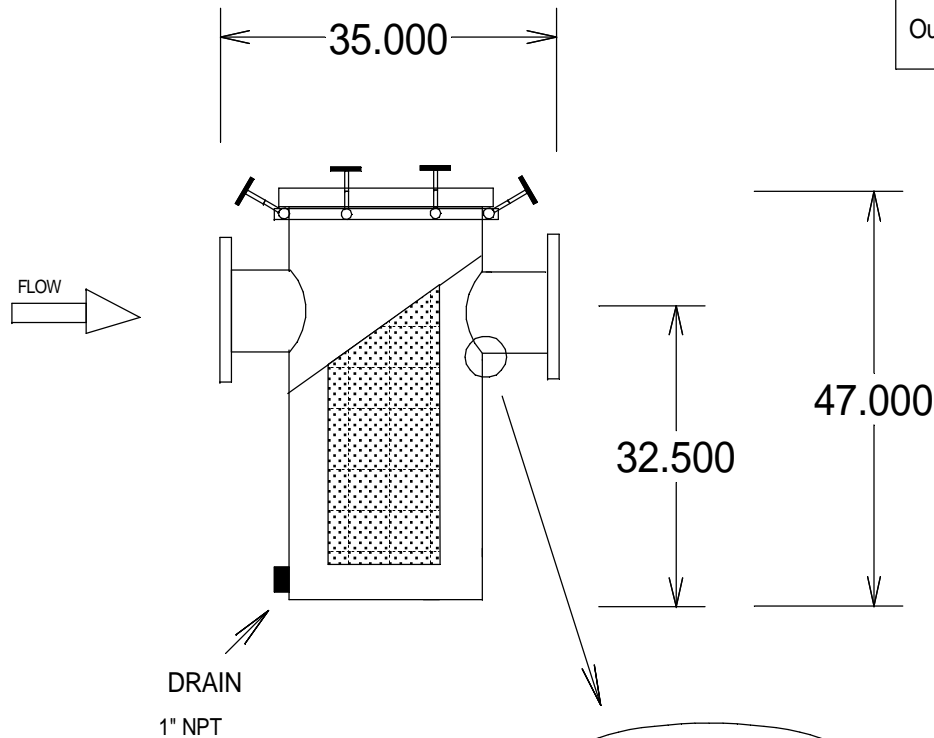

See Detail A

### Detail A

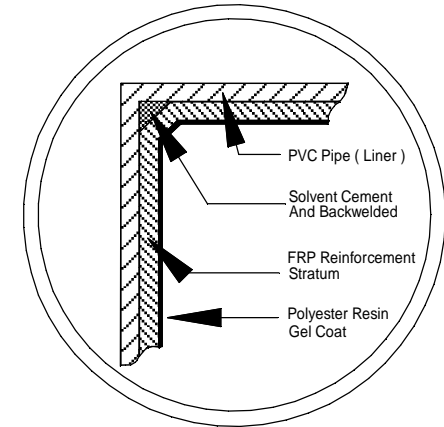

This drawing represents the design & engineering efforts of Fluidtrol Process Technologies, Inc. it is loaned in confidence and is not to be reproduced or used in any way detrimental to Fluidtrol Process Technologies, Inc without written permission.

FLUIDTROL PROCESS TECHNOLOGIES, INC. HUNTSVILLE, AL 35811	
DRWN: TT	SW SERIES AQUATIC STRAINER
DATE: 6-21-10	14" X 14"
MODEL: SW116114031	DRWG: SW116114031