

| SPECIFICATION | |
|------------------------------------|----------------------------------|
| Body :FRP/PVC | MAX. PRESSURE: 50 PSI * |
| Basket: 304 SS, 1/8" Perf | MAX. TEMPERATURE: 140 Deg F |
| Basket Matl: flg-12 GA/ Perf-16 GA | BASKET/PIPE AREA: 10.2 : 1 |
| Gasket: Neoprene | Open Basket Area: 4.1 : 1 |
| Inlet: 10" 150# ANSI Flange | Cover: 1" Acrylic With 1/2" Vent |
| Outlet: 8" 150# ANSI Flange | Lid Closer: Tee Handles 304 SS |

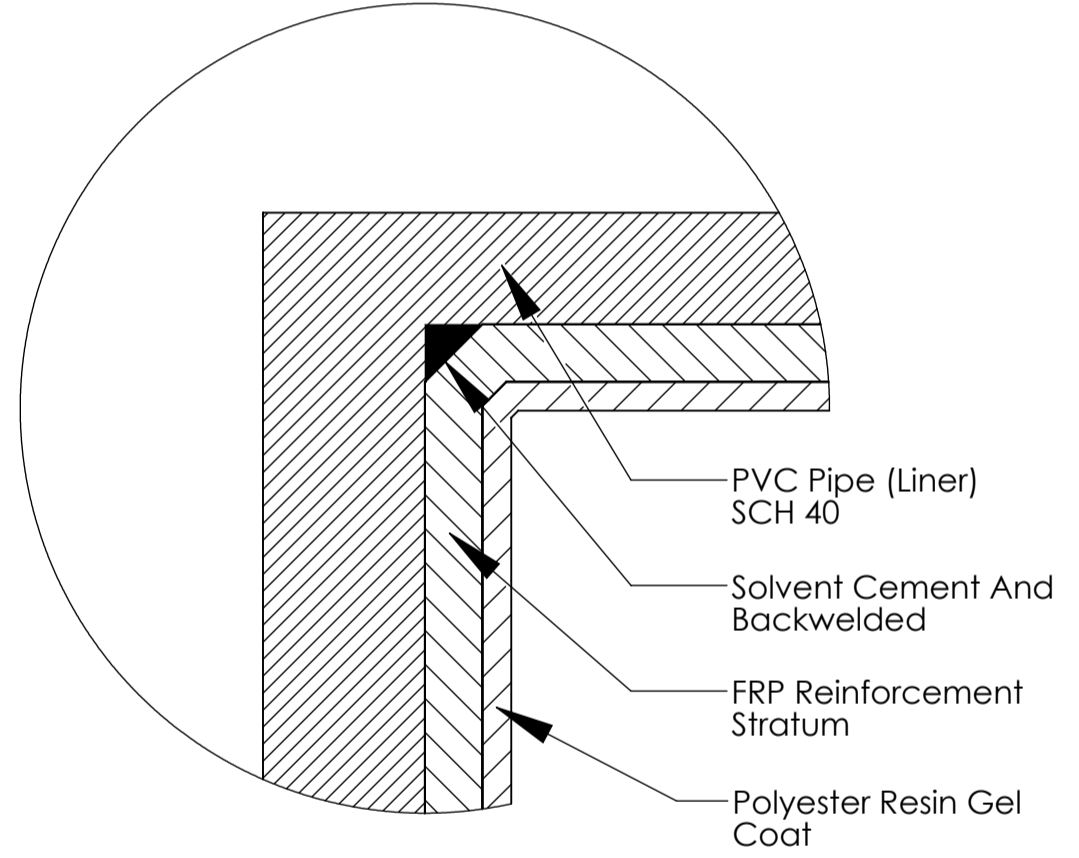
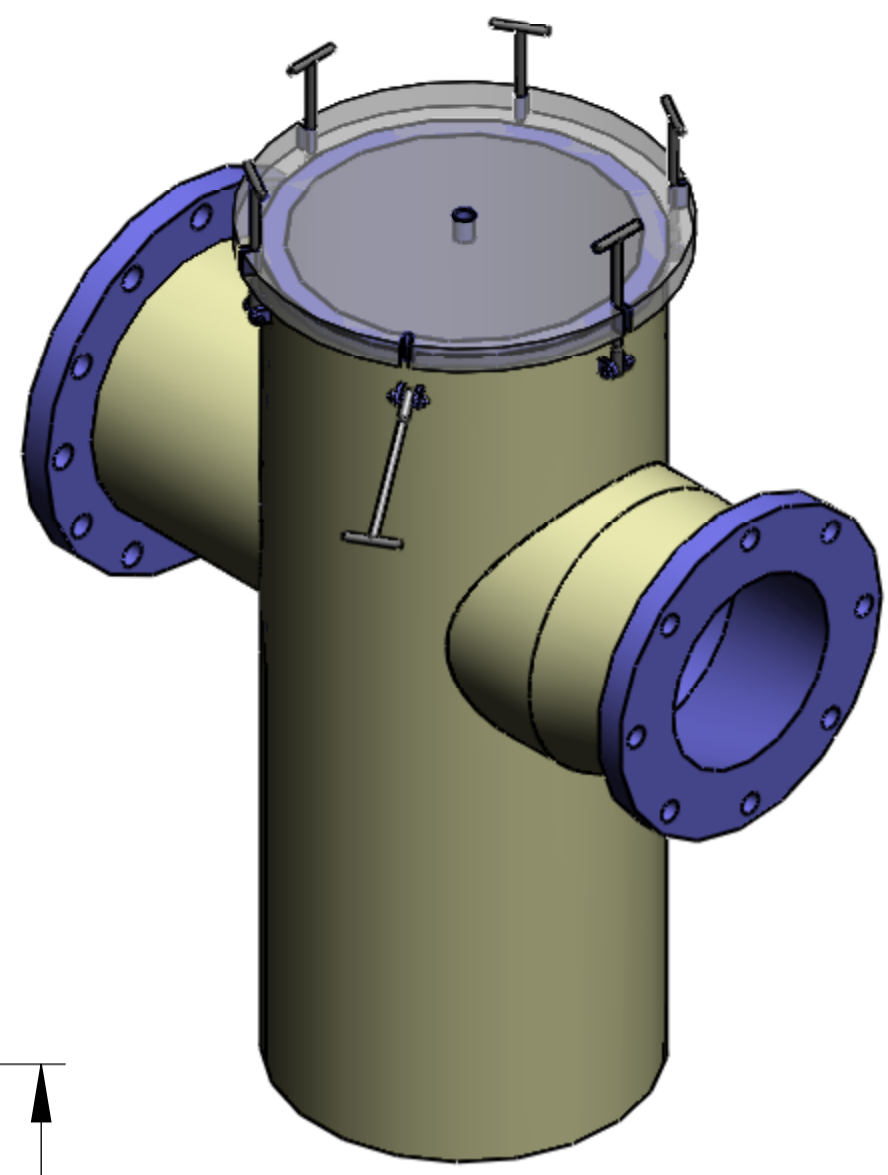
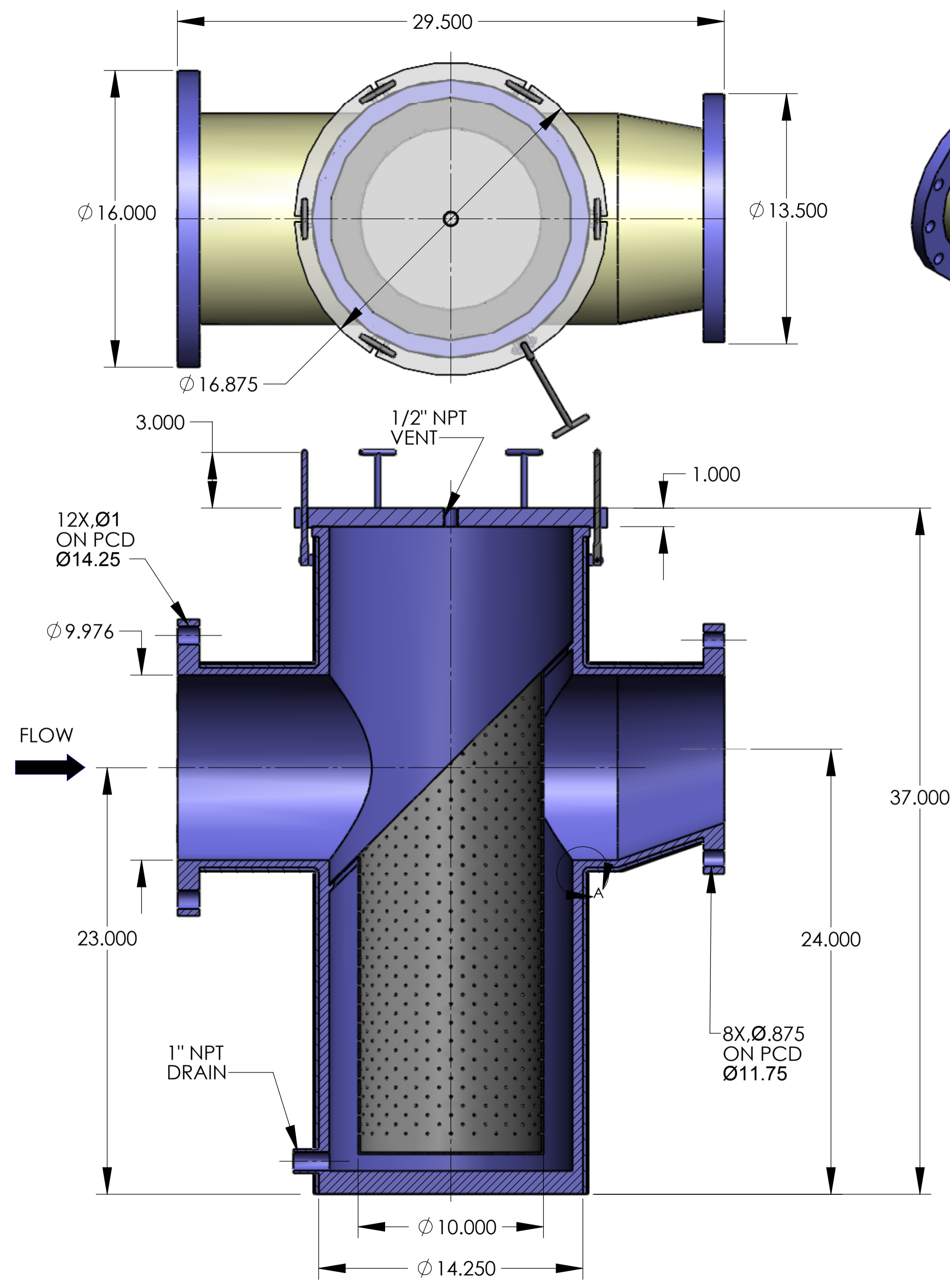

FLUIDTROL PROCESS TECHNOLOGIES, INC.
HUNTSVILLE, AL 35811

DRAWN: SS
DATE: 11-1-10

RSW SERIES AQUATIC STRAINER
10"X8"

This drawing represents the Design & engineering efforts of Fluidtrol process Technologies, Inc. it is loaned in confidence and is not to be reproduced or used in anyway detrimental to Fluidtrol process Technologies, Inc Without Written Permission

MODEL: RSW116110831

DRWG RSW116110831 852-06108SC

8 7 6 5 4 3 2 1 Sales No